

Z1

design office



LACQUERED BACK PANELS

Straight structural back panels made of 30mm lacquered melamine faced chipboard (MFC) finished with 2mm impact resistant ABS edges in a matching matt lacquer finish. MFC density 670/730 kgs per cubic meter. Fittings provided.
 Corner structural back panels made of 30mm lacquered melamine faced chipboard (MFC) finished with impact resistant ABS edges in a matching matt lacquer finish. MFC density 670/730 kgs per cubic meter. Straight and corner back panels are 45 degree mitre cut and joined together to form a 90 degree angle using fittings provided.

LACQUERED WORKTOPS

Made of 30mm lacquered melamine faced chipboard (MFC) finished with 2mm impact resistant ABS edges in a matching matt lacquer finish. Corner worktops are 45 degree mitre cut and joined to corner back panels to form a 90 degree angle using provided fittings. Straight worktops are joined to straight back panels using brackets provided. MFC density 670/730 kgs per cubic meter.

LACQUERED COUNTER MODULE

Made of 18mm and 30mm lacquered melamine faced chipboard (MFC) finished with 1 mm and 2mm impact resistant ABS edges in a matching matt lacquer finish. A counter module is formed of 45 degree mitre cut panels joined together to form 90 degree angles using fittings provided. MFC density 670/730 kgs per cubic meter.

Finish options:

LB White	LL Grey White	LS Silk Grey	NK Light Beige	LE Beige	LT Beige Grey	NU Dark Brown	NW Ocher
LA Orange	NJ Burnt Orange	LH Flame Red	LR Purple Red	LI Black Red	LZ Sapphire Blue	NQ Cobalt Blue	LC Pigeon Blue
LD Ocean Blue	LP Pine Green	NV Olive Green	LF Telegrey 4	LG Grey	LO Umbra Grey	LN Traffic Black	

Production lead time: 5 weeks excluding delivery time. Apart from the shown finish options any RAL color can be made to order.

METAL PARTS

Tubular support leg made of 50×50mm 1.5mm steel tube with a 2mm steel support plate. Leg and plate are supplied powder coated.

Outer metal plinth supplied as standard, made from 6060 extruded anodized aluminium fitted to the back panels using clips provided.

Finish options:



LIGHTING (OPTIONAL EXTRA)

Optional flexible cool white LED strip, can be bent or cut without compromising on functionality. Easy peel-and-stick backing mounts to the lower end of plinths. Includes an ON/OFF switch.

Optional flexible cool white LED strip set within a 6060 extruded anodized aluminium profile covered with translucent anti-glare polycarbonate. Mounts to the lower end of counter modules.

24V LED power supply. 2mtrs long power cable. Fixed using self-tapping screws to the inner face of the straight and corner structural modules.



Z1 RECEPTION WITH ENDING LOW COUNTER

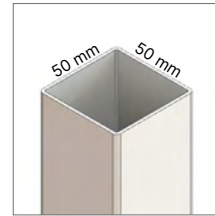
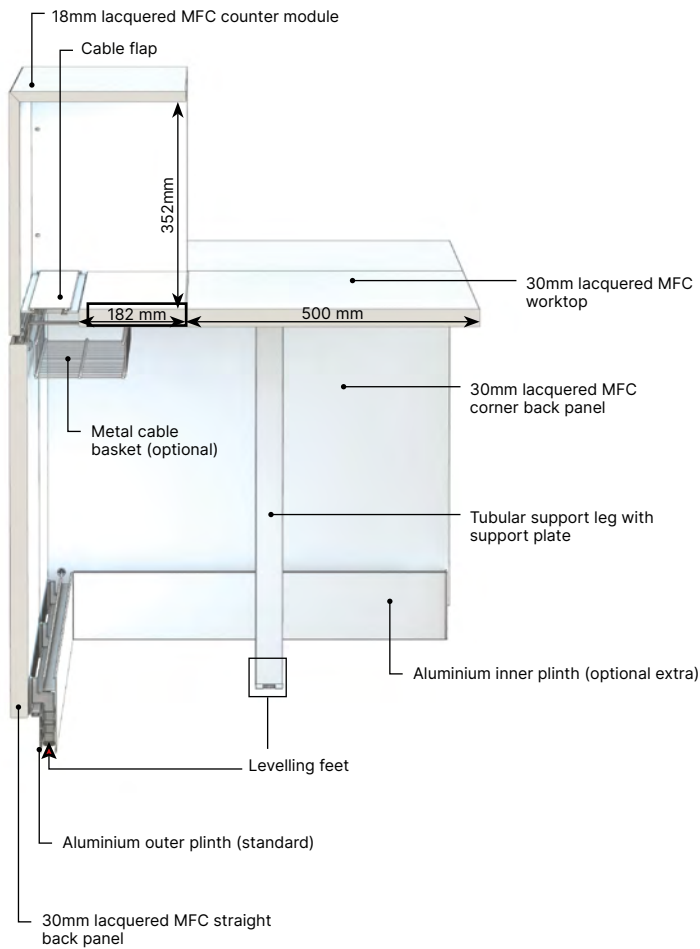

Tubular support leg made from 50x50mm 1.5mm thick steel tube supplied with 3mm steel support plate.

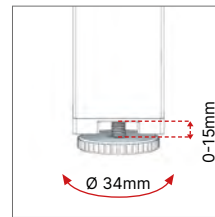

Levellig feet for middle leg, Ø 34mm, 0-15mm travel.

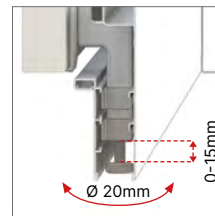

Polyethylene levelling feet, Ø 20 mm, 0-15mm travel.

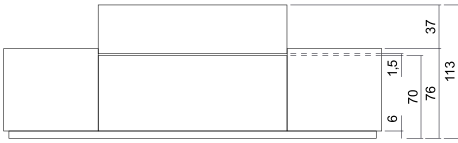

SYMMETRICAL CONFIGURATIONS

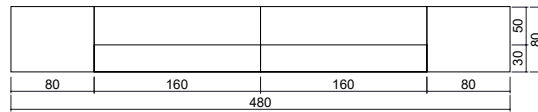
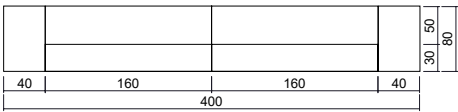
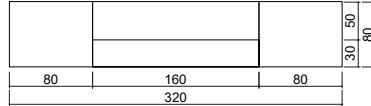
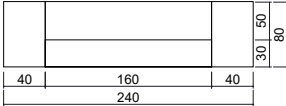

ASYMMETRICAL CONFIGURATIONS

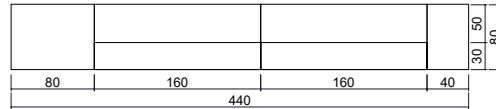
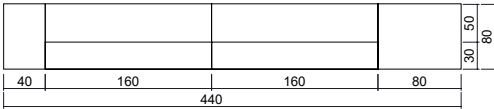
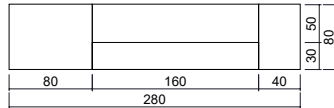
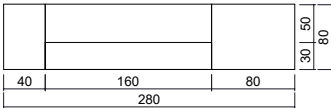

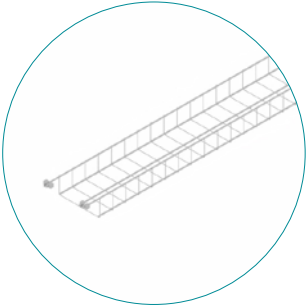

Metal cable basket



Translucent Abs cable spine



Peel-and-stick translucent polycarbonate cable riser



MATERIALS AND RECYCLABILITY

MFC panels used for Z1 range tables are solely manufactured with 100% recycled wood and fully meet requisites of formaldehyde low emissions (CARB Quality Award CATAS Certificate). Resins used for panels and melamines are free of SVHC substances (to be found in the ECHA list updated as of 12/01/2017).



CERTIFICATES

Constantly receptive to market requirements, Quadrifoglio Sistemi d'Arredo pay special attention on quality and safety contents in order to provide high products and services. The Company has reached certifications UNI EN ISO 9001/2015, UNI EN ISO 14001/2015 and UNI EN ISO 45001/2018 to confirm his policy. Our products are certified and ensured by FSC™ and ECOLOGICAL PANEL.

COMPANY WITH
MANAGEMENT SYSTEM
CERTIFIED BY DNV
ISO 9001 • ISO 14001
ISO 45001



GREEN ENERGY

The Company had installed the photovoltaic system with 4.500 solar panels in a 7.350 m² surface that covers almost entirely the factory. The photovoltaic is able to produce 1Mw of a quiet green energy, that does not harm the environment and is waste-free. With his high production capacity the photovoltaic allows us to reduce emissions in the atmosphere of all those polluting substances and to those that contribute to the greenhouse effects. Consequently, such measures make us save every year 180 tonne of petrol oil, 440 tonne of CO₂, 514kg of sulphur dioxide, 448 kg of nitrogen oxide and 23kg of dust.



TRANSPORT

Detachable systems. Volumes that facilitate the optimization of space. Maximum reduction of energy consumption by transport.