

Technical description

1. Dimensions / Weight

1.1. Armchairs

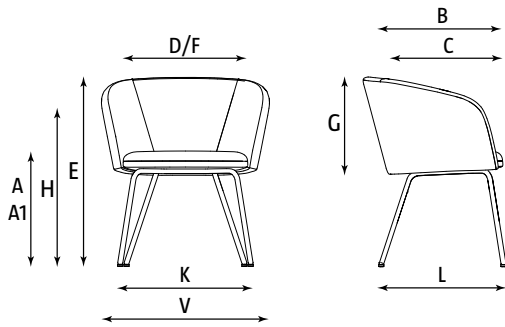

- A – Seat height
- A1 – Seat height according to standard PN-EN 16139
- B – Seat depth
- C – Seat surface depth
- D – Seat width
- E – Overall height
- F – Backrest width
- G – Backrest length
- H – Armrest height
- K – Base width
- V – Overall width
- L – Product overall depth

	DIMENSIONS [mm]												WEIGHT (kg)
	A	A1	B	C	D	E	F	G	H	K	V	L	
NAUDU ARMCHAIR CFSX-ROD UPH	475	435	470	450	500	770	500	380	720	535	670	600	9,9
NAUDU ARMCHAIR 4L UPH	475	435	470	450	500	770	500	380	720	550	670	590	10,7
NAUDU ARMCHAIR 4LLGW UPH	475	435	470	450	500	770	500	380	720	530	670	580	10,5

1.2. Sofas

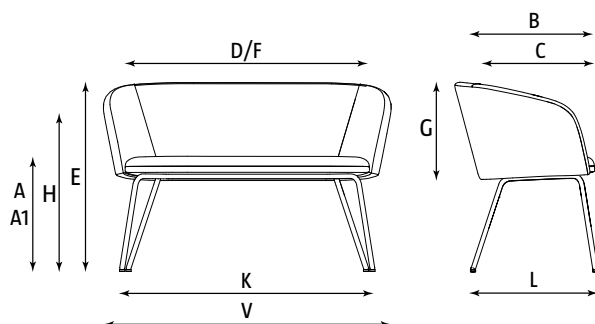

- A – Seat height
- A1 – Seat height according to standard PN-EN 16139
- B – Backrest width
- C – Seat surface depth
- D – Seat width
- E – Overall height
- F – Backrest width
- G – Backrest length
- H – Armrest height
- K – Base width
- V – Overall width
- L – Product overall depth

	DIMENSIONS [mm]												WEIGHT (kg)
	A	A1	B	C	D	E	F	G	H	K	V	L	
NAUDU SOFA CFSX-ROD UPH	475	435	470	450	1010	770	1000	380	720	1035	1170	600	22,3
NAUDU SOFA 4L UPH	475	435	470	450	1010	775	1000	380	720	1050	1170	590	20,7
NAUDU SOFA 4L LGW UPH	475	435	470	450	1010	775	1000	380	720	1030	1170	580	19,8

Technical description

2. Materials / Versions

2.1. Base / Frame

2.1.1. Armchairs and sofas

4-leg frame – made of steel tube $\varnothing 22 \times 2$ mm.

Sled frame – made of rod $\varnothing 11$ mm.

Finish options:

- powder-coated in Signal white colour RAL 9003 (E-WS),
- powder-coated in Jet black colour RAL 9005 (E-BL),
- chromium plated (E-CR).

4-leg wooden frame – legs made of solid beech wood, bars made of beech plywood.

Finish options:

- natural beech (E-1.007),
- stained beech with slightly visible wood grains (E-2.***).

2.2. Glides

2.2.1. Armchairs and sofas

4-leg frame: Self-leveling glides for soft floors (GBP) as standard or self-leveling glides with felt for hard floors (GBPF) as an option.

Sled frame: Transparent glides for soft floors (GT) as standard or with felt for hard floors (GTF) as an option.

4-leg wooden frame: Glides for soft floors (GB) as standard or with felt for hard floors (GBF) as an option.

2.3. Seat and backrest

2.3.1. Armchairs and sofas

Upholstered shell (backrest with integrated armrests and a connected seat) (UPH)

Structure of backrest with integrated armrests is made of 8-layer beech plywood, thickness 9 mm, covered with flame retardant cut foam, thickness 20-40 mm and density 50 kg/m³ (front) and cut foam, thickness 10 mm and density 35 kg/m³ (back).

Seat structure is made of 12-layer beech plywood, thickness 18 mm, covered with cut foam, thickness 45 mm and density 40 kg/m³. Fully upholstered shell (A-PLUS) as standard.

3. Packaging

Armchair – 1 piece per box (assembled).

Sofa – 1 piece per box (assembled).

4. Technical regulations, approvals and quality marks (pending)

Remodex (durability certificate) – approvals compliant with EN 13761, EN 1728, EN 1022, EN 15373 level 2.

5. Rules of upholsteries matching.

Upholstery type is the same for each upholstered element.

Upholstery colour can be mixed for the inner side of the shell and seat (one colour) and the outer side of the shell (one colour).